

VWT Jig

Universal Electric Wheel Motor Jig

(Part No. TL02095A)



The Trilift® Universal Electric Wheel Motor Jig is designed to assist with the removal and installation of electric wheel motors on trucks and loaders.

The jig is bolted to the Trilift® Variable Work Table and is currently adaptable to suit GE series AC and DC wheel motors including 830-5. The jig is supplied complete with chains and turnbuckles for the retaining of the assembly.

Features and Benefits

- Lifting lugs for ease of handling
- Adjustable rollers for differing size wheel motors
- Safety chains and turnbuckles supplied
- 4 inch packer included

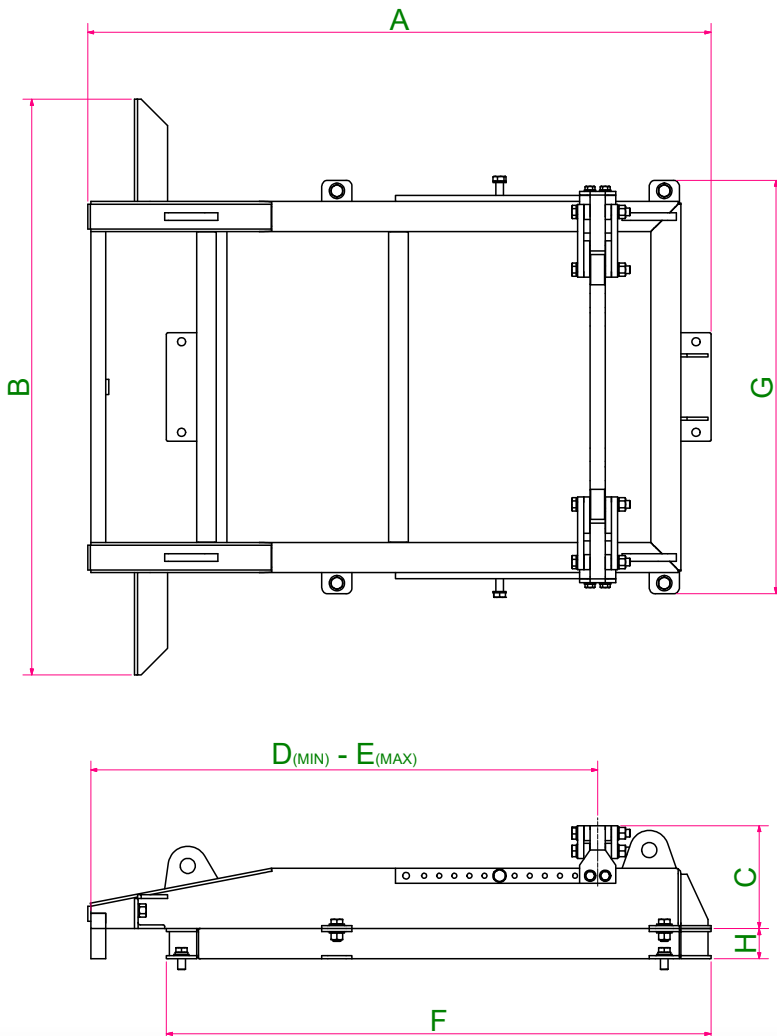

Specifications

The Trilift® Electric Wheel Motor Jig is compliant with the following standards:

- AS 3990 Mechanical Equipment - Steelwork
- AS4991 Lifting devices

Key Operating Data

Working Load Limit	33,069lbs	15,000 kg
Tare weight	1,168 lbs	530 kgs

Key Dimensions (approximately)

A	Length	81in	2066mm
B	Width	75in	1908mm
C	Height	13in	341mm
D	Cradle carrier min	44in	1130mm
E	Cradle carrier max	66in	1680mm
F	Packer(s) length	71in	1805mm
G	Packer(s) width	54in	1370mm
H	Packer height	4in	100mm

