

Belly Pan Hoist Tooling

Pump Jig (Part No. TL10021)

The Trilift® Pump Jig has been developed to assist in the removal and installation of hydraulic pumps from beneath large mining trucks eg. steering and hoist pumps.

Key Operating Data

Working Load Limit	881 lbs	400 kgs
Tare Weight	59 lbs	27 kgs

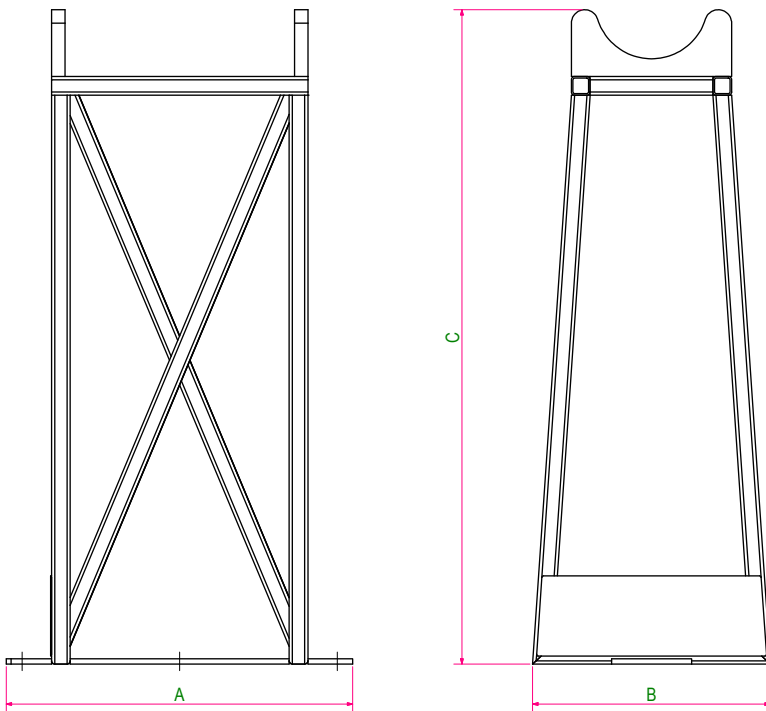

Key Dimensions (approximately)

A	Length	26in	650mm
B	Width	18in	445mm
C	Height	48in	1225mm



Maintenance Support Equipment

Features

- Eliminates manual handling
- Integrates with Trilift® Belly Pan Hoist (Part No. TL10023)

The Pump Jig is compliant with the following standards:

- AS 3990-1993 Mechanical equipment-steelwork.
- AS/NZS 1554.1:2011 Structural Steel Welding.
- AS/NZS 3678:2011 Hot-rolled plates, floor plates and slabs
- AS/NZS 3679.1:2010 Hot-rolled bars and sections.
- AS/NZS 1163:2009 Cold formed structural steel hollow sections.
- AS/NZS 1252:1996 High strength steel bolts with associated nuts and washers for structural engineering

