

VWT 15 Jigging

Multijig 15 & Universal Cylinder Clamp

The Multijig 15 attachment (Part No. TL02008) is designed to bolt directly on the pre-drilled table of the Variable Work Table 15 to aid in the removal of a variety of heavy earthmoving components.

The Universal Cylinder Clamp (Part No. TL02006) when used in conjunction with the Multijig 15 is designed to assist with the safe and efficient handling of large hydraulic cylinders, including hoist cylinders and rear struts.

This jigging is used to provide additional movement functions for the Trilift® VWT 15 to enable the accurate removal of components from large trucks, loaders and other items of plant.

Trilift® Multijig 15



Designed to integrate with the Trilift® VWT 15 the **Multijig 15** bolts directly to the pre-drilled table to assist with the removal of components.

Component handling includes:

Multijig 15 only

- Front Hub and Strut assemblies

Multijig 15 with Cylinder Clamp

- Hoist cylinders
- Rear suspension struts



Trilift® Universal Cylinder Clamp



The **Universal Cylinder Clamp** (Part No. TL02006) when used in conjunction with the Multijig 15, is designed to assist with the safe and efficient handling of large hydraulic cylinders, including hoist cylinders and rear struts.

Features

- Working load limit capacity of 5511 lbs retracted and 4078 lbs extended
- Telescopic reach adjustment
- Adjustable wire ropes to clamp cylinders of varying diameters
- Simple, quick attachment to the head of the Multijig 15

Featuring a telescopic arm, the reach of the clamp can be easily altered for two lengths of operation by pinning the adjustable arm to the required length. To clamp a cylinder, tension adjustable wire ropes are fitted to the head of the Trilift® Universal Cylinder Clamp.



Specifications

The Multijig 15 and Universal Cylinder Clamp are compliant with the following standards:

- AS 3990-1993 Mechanical equipment—Steelwork.
- AS/NZS 1554.1-2004, Structural Steel Welding.
- AS 1418.1-2002 Cranes, hoists and winches
- AS 1163- Structural steel hollow sections.
- AS/NZS 1594, Hot-rolled steel flat products.
- AS/NZS 3679, Structural Steel.
- AS/NZS 1252 High strength steel bolts with associated nuts and washers for structural engineering.

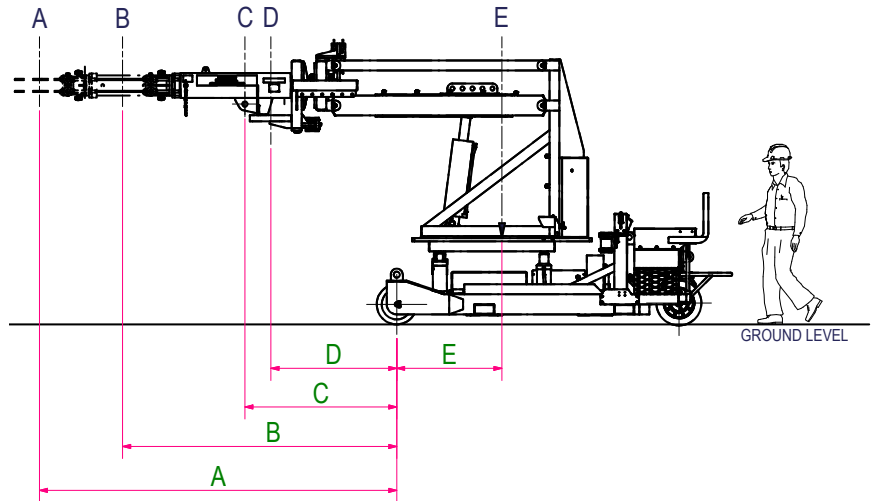

Key Dimensions (approximately)

A	Length	129in	3275mm
B	Width	49in	1250mm
C	Height	71in	1780mm
D	Lowered height	34in	851mm
E	Raised height	94in	2400mm
F	Jaws- retracted	16in	398mm
G	Jaws- extended	54in	608mm
H	Head rotation	17 degrees	-

WORKING LOAD CHART

LOCATION	DESCRIPTION	DIST (mm)	DIST (in)	LOAD (KG)	PSI
A	CYLINDER CLAMP EXTENDED	3570	141	1,850	625
B	CYLINDER CLAMP RETRACTED	2740	108	2,500	625
C	LIFTING LUG	1517	60	4,600	650
D	JAWS	1258	50	5,000	650
E	MAXIMUM LOAD ON TABLE	1052	41	15,000	N/A

