

VWT Jig

Universal Large Wheel Motor Jig (Part No. TL02093)

The Trilift® Universal Large Wheel Motor Jig is bolted to the Trilift® Variable Work Table XC20/25/30 and used to assist with the removal and installation of large AC wheel motors on most makes and models of ultra-class trucks (with pay loads in excess of 240 tonne).

The Trilift® Universal Large Wheel Motor Jig is fitted with fork tyne recesses so that the jig can be used as a transportation frame. The jig is supplied complete with chains and turnbuckles for the retaining of the assembly.

Key Operating Data

Working Load Limit	28,000 kg	61729.4lbs
Tare weight	930 kg	2050.3lbs

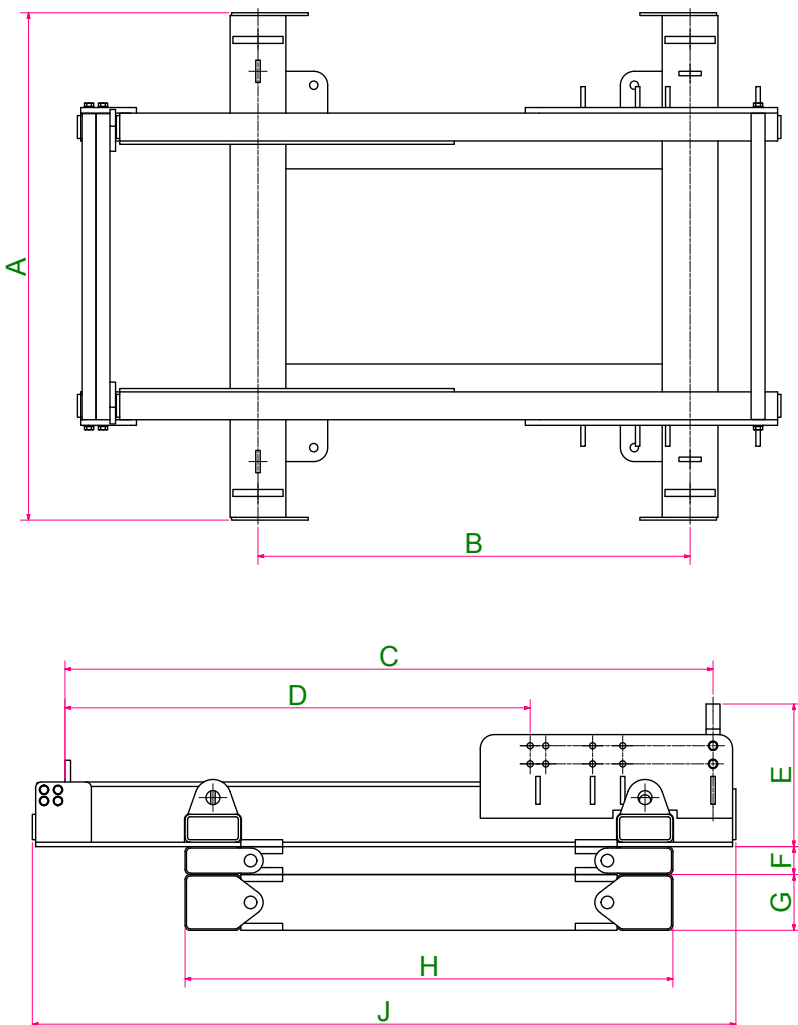

Features and Benefits

- Fork tyne pockets & lifting lugs for ease of handling
- Adjustable for varying size wheel motors
- Safety chains and spacers supplied

Key Dimensions (approximately)

A	Overall width	1820mm	71.6in
B	Fork tyne pocket width	1550mm	61in
C	Max. Adaptor length	2325mm	91.5in
D	Min. Adaptor length	1669mm	65.7in
E	Jig height	512mm	20.2in
F	100mm packer	100mm	3.9in
G	200mm packer	200mm	7.8in
H	Packer length	1750mm	68.8in
J	Overall length	2524mm	99.3in

Specifications

The Trilift® Large Wheel Motor Jig is compliant with the following standards:

- AS 3990:1993 - Mechanical Equipment Steelwork
- AS/NZS 1554.1:2004 - Structural Steel Welding
- AS 1418.1-2002 - Cranes, Hoists and Winches
- AS 1163 - Structural Steel Hollow Sections
- AS/NZS 1594 - Hot Rolled Steel Flat Products
- AS/NZS 3679 - Structural Steel
- AS/NZS 3679.1:2011 - Hot Rolled Bars and Sections
- AS/NZS 1252 High strength steel bolts with associated nuts and washers for structural engineering

