

Twin Jack Stand Model 300

The Trilift® Twin Jack Stand Model 300 (Part No. TL13130) is a versatile, heavy duty Jack and Stand designed to lift and support heavy earth moving equipment, such as dozers and trucks, to a combined working load limit of 300 tonne.

Once the load is raised, spring loaded jaws lock into the teeth on either side of the jack, transforming the Twin Jack Stands into **certified support stands**. The inclusion of this locking mechanism ensures compliance with Australian/New Zealand Standard AS/NZS2538-1995, Vehicle Support Stands. This feature eliminates the difficult, time consuming and dangerous procedure of making the change from a jack to a support stand and improves productivity by halving the time it takes to perform the task.



Versatile - by simply removing the centre carriage each turret can be used as a Single Jack Stand Model 150.

ALL-IN-ONE
Jack & Stand
Improving
productivity
by **50%**



Spreads Heavy Loads

Unlike traditional jacks or stands the unique design of the Trilift® Twin Jack Stand Model 300 includes a broad 27.5inch² /700mm² base-plate to spread heavy loads. This Loading Chart shows the Single Jack Stand's lifting capabilities in relation to the thickness of concrete or other types of hard stand surface.

SURFACE THICKNESS	MPA	LOADING
12 inch/300mm	40	150 T
10 inch/250mm	40	116 T
7.8 inch/200mm	40	81 T
6 inch/150mm	40	52 T



Features and Benefits

- Jack and certified Work Stand combined in a single unit
- Broad based to spread heavy loads
- Adjustable jack widths using centre carriage
- Self-engaging locking jaws for increased safety
- Easy placement under a vehicle using a pallet jack
- Simple release of jaws prior to load lowering
- Remote Power Pack with 20"/6m hoses

Key Operating Data

	SINGLE	TWIN
Working Load Limit	150t	300t
Tare Weight	1433lbs/650kgs	3968lbs/ 1800kgs

Key Dimensions

A-B Jack Height (Retracted - Extended)	31 - 47in	800 - 1206mm
C-D Adaptor 1	41 - 57in	1047 - 1453mm
E-F Adaptor 2	45 - 61in	1142 - 1548mm
G-H Adaptor 3	48 - 64in	1212 - 1618mm
I-J Adaptor 4	49 - 65in	1257 - 1663mm
K-L Adaptor 5	52 - 68in	1327 - 1733mm
M 150T Jack Length	28in	700mm
N 150T Jack Width	30in	750mm
O Pallet Jack Tyne-Width	21in	525mm
P-Q 300T Twin Jack Turret Width (Retracted - Extended)	64 - 78in	1620 - 1980mm
R-S 300T Twin Jack Overall Width (Retracted - Extended)	93 - 107in	2370 - 2730mm

Adaptor Jacking Heights

Each Jack is supplied with adaptors to achieve various lifting heights to a maximum of 68.2 inch / 1733mm. Custom adaptors are available upon request. With the use of the Turret and Adaptors - 5 additional height adjustments are available.

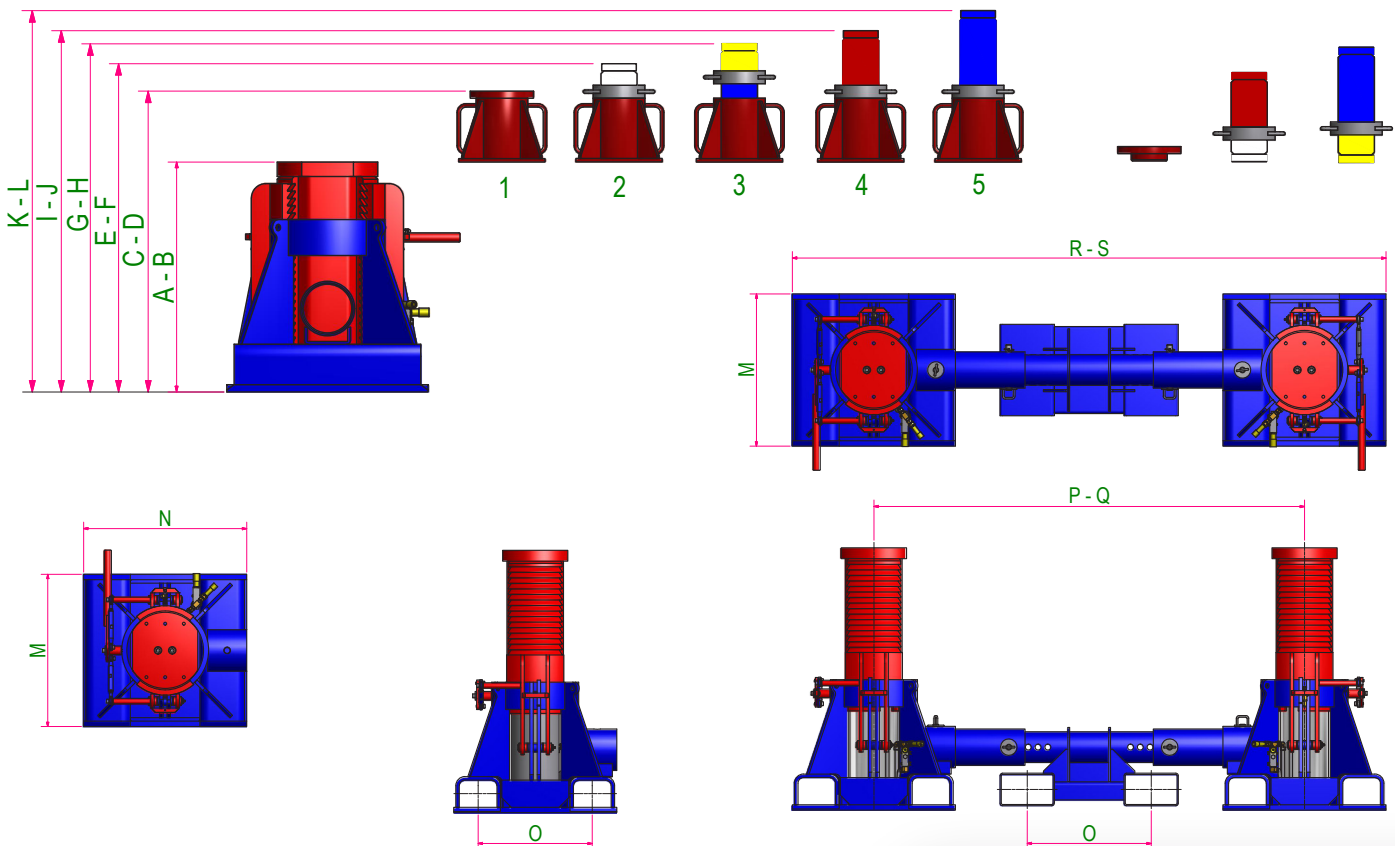

Power Options

To complement the Trilift® Twin Jack Stand Models 100 and 300 we have developed Power Packs allowing the operator to jack both turrets simultaneously or individually, with adjustable tuning.

The Power Pack's 20 foot / 6 metre long hoses allow the operator to control the Twin Jack Stand from a safe distance and are connected using "quick connect" style connectors. These power packs are available in both Electric and Pneumatic power options.

Electric Power Pack *(Part No. CP03011A)*

Key Operating Data

Standard supply voltage	415VAC, 50Hz, 3 Phase
Custom voltage	on request
Oil reservoir capacity	21.1 gal / 80 litres
Pressure (Max)	10,000 psi (raise) 5,000 psi (lower)
Dimensions	32.5inH/25.3inL/28.5inW 827mmH/643mmL/725mmW
Pallet Jack tyne width	20.6 in / 525mm

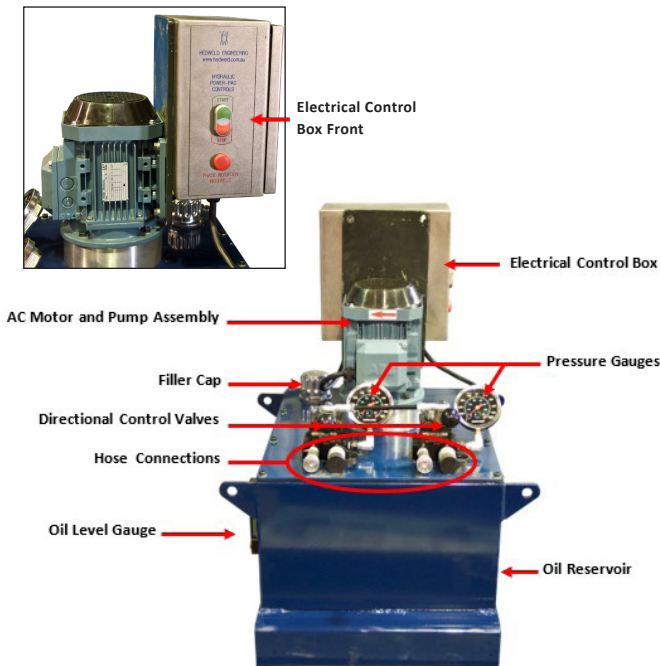

Like the Jack Stands the Power Packs can be moved with a:

- Pallet Truck - Manual (Part No. TL13250),
- Pallet Truck - Electric (Part No. TL13257) or
- a standard fork truck.



Electric Power Packs

Pneumatic Power Packs

Pneumatic Power Pack *(Part No. CP03015A)*

Supplied with air filter, lubricator and regulator.

Key Operating Data

Oil reservoir capacity	21.1 gal / 80 litres
Control valve connectors	10,000psi
Air pressure required	110psi & 130CFM (Min 80psi)
Operating Pressure (Max)	10,000 psi (raise) 5,000 psi (lower)
Dimensions	31.1inH/25.3inL/28.5inW 792mmH/643mmL/725mm W
Pallet Jack tyne width	20.6 in / 525mm

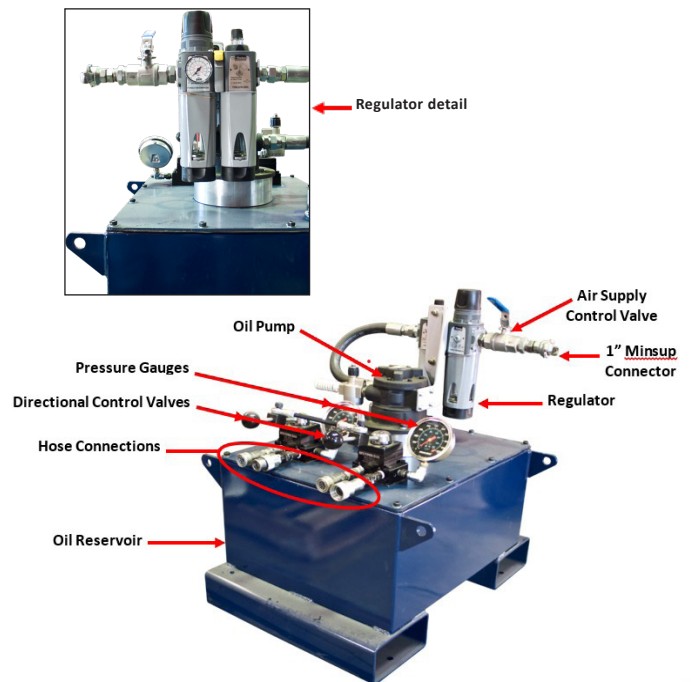

Twin Jack Stand Model 100T inclusions (Part No. TL13101)

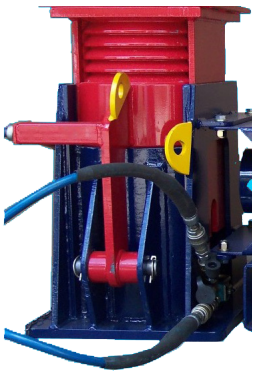

1 X Single 50T Jack
Left
(Part No. TL13005)

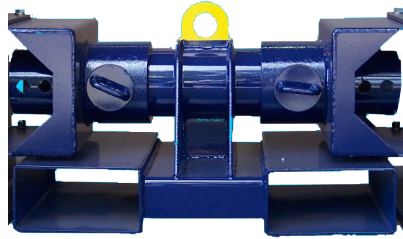

1 X Centre Carriage Adjustable
Width

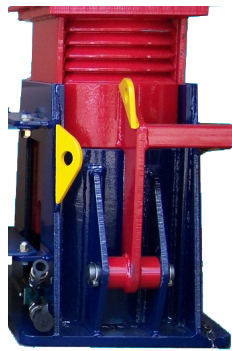

1 X Single 50T Jack
Right
(Part No. TL13006)



2 X Adjustable
Height Swivel
Cap Adaptors
(Part No. TL13255)

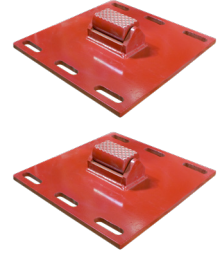

2 X Flat
Swivel Cap
Adaptors
(Part No. TL13261)

Twin Jack Stand Model 300T inclusions (Part No. TL13130)



1 X Single 150T Jack
Left
(Part No. TL13001)



1 X Centre Carriage Adjustable
Width



1 X Single 150T Jack
Right
(Part No. TL13003)



2 X Turrets
(P/N. HW75434)



2 X Turret Cap
Adaptors
(P/N. HW75437)



2 X Short Adaptors
(P/N. HW75446)



2 X Long Adaptors
(P/N. HW75447)

Full Adaptor Kits available

Power Options (required)



1 X Electric Power Pack
(Part No. CP03011)

OR



1 X Pneumatic Power
Pack (Part No. CP03015)

Pallet Trolley (optional)



1 X Manually
Operated WLL 2.5T
(Part No. TL13250)

OR

1 X Electrically
Operated WLL 1.5T
(Part No. TL13257)