

EL-24H

The Safe-Away[®] EL-24H Electric Ladder Access System has been specifically designed to provide safe and convenient access for operators and maintenance personnel accessing Cat 24H graders.

Without the need for a hydraulic power pack the electric ladder raises to a safe position when the vehicle is in motion. They are easy to install and utilise a simple on board control system without compromising the safety features you expect of Safe-Away[®] Access Systems.

Easy to
operate &
competitively
priced



Safety & Efficiency

The **Safe-Away® EL-24H** has been specifically designed to provide:

- A 62° ladder offering safer access and egress while carrying tools.
- A design to raise safely out of the way while the vehicle is in motion.
- Fixed handrails to give three points of contact.
- Easy installation.
- Low maintenance.
- No hydraulics.
- Compact designs.
- Safe and user friendly.
- Cost effective.



Ladder Features



- **Boarding Light and Wiring Harness Kit.** The LED boarding light will stay on for an adjustable/preset period.



- Incab **touch screen** controlling the up and down ladder functions with a battery charge display.
- The **DVC710** is the master control for the electric ladder input/out and is located with the **Electrical Control Module (ECM)**.
- The DVC710 is encapsulated in the ECM **stainless steel box** to withstand harsh operating environments.
- **Momentary Operation** is available with the **Park Brake Alarm**. The alarm will activate when the park brake is released if the ladder is not fully raised and in its rest position.
- **Batteries** power the ladders. The host equipment's main power recharges these batteries when host is in use.

ECM Functions

- The **state of charge** is regulated by the DVC710.
- The **operational voltage** is 24VDC with a maximum current draw of 12A.
- The DVC710 has its own Controller Area Network (CAN) which is used by the Incab Controller.
- The system is **compatible with all CAN-BUS** and J1939 components.
- Reverse polarity protection.
- Status LED indicator.



Designed to suit your fleet

This **Safe-Away® EL-24H Ladder** retraction mechanism consists of linkage arms, which enables the lower ladder to fold up upon the upper ladder section.

The EL-24H Ladder has the following features:

- Ladder assembly and handrails
- 24V electric actuator
- Mounting brackets specially designed to fit the Cat 24H grader
- Another safety addition is the door safety switch which is connected to the cab door to ensure the ladder doesn't operate when the door is opened.



EL-24H Electric Ladder shown above in the retracted position. This picture shows you the specialised mounting brackets.



The image left shows the EL-24H Electric Ladder in the extended position. From this angle you can clearly see the Boarding Light.

Optional extras

1. Additional Raise and Lower Control Panel Kit



A remotely mounted control panel designed to enable the raise and lower operation from outside of the vehicle's cab, or at a position accessible from ground level. Encased in protective aluminium box.

2. An **Emergency Stop** can be fitted to stop the ladder at any point in the raise/lower cycle. Motion can be resumed by pressing a directional button.

3. An external **Audible Alarm Kit** is activated by pressing the up or down directional switch.



4. An optional **Inhibit Kit** can be used to control vehicle functions such as (but not limited to) slew and propel on excavators, propel on electric drive trucks and blade inhibit on graders.



5. Momentary Operation

Safe-Away® Access Systems can be supplied with momentary operation.

Specifications

This Safe-Away® EL-24H has been designed and manufactured to comply where practicably possible with the relevant sections of the following standards:-

SAE J185_200305 ISO 2867:2011 ANSI Z535.4-2007 ANSI A14.2-2007 AS 3868-1991 AS 5327:2019 AS 1657-2013

EL-24H Dimensions

Steps	Deck Height Maximum	Lowered Reach Limit	Raised Ground Clearance Minimum	Raised Extremity
9	2404mm 94.6in	1331mm 52.4in	1195mm 47.0in	969mm 38.1in

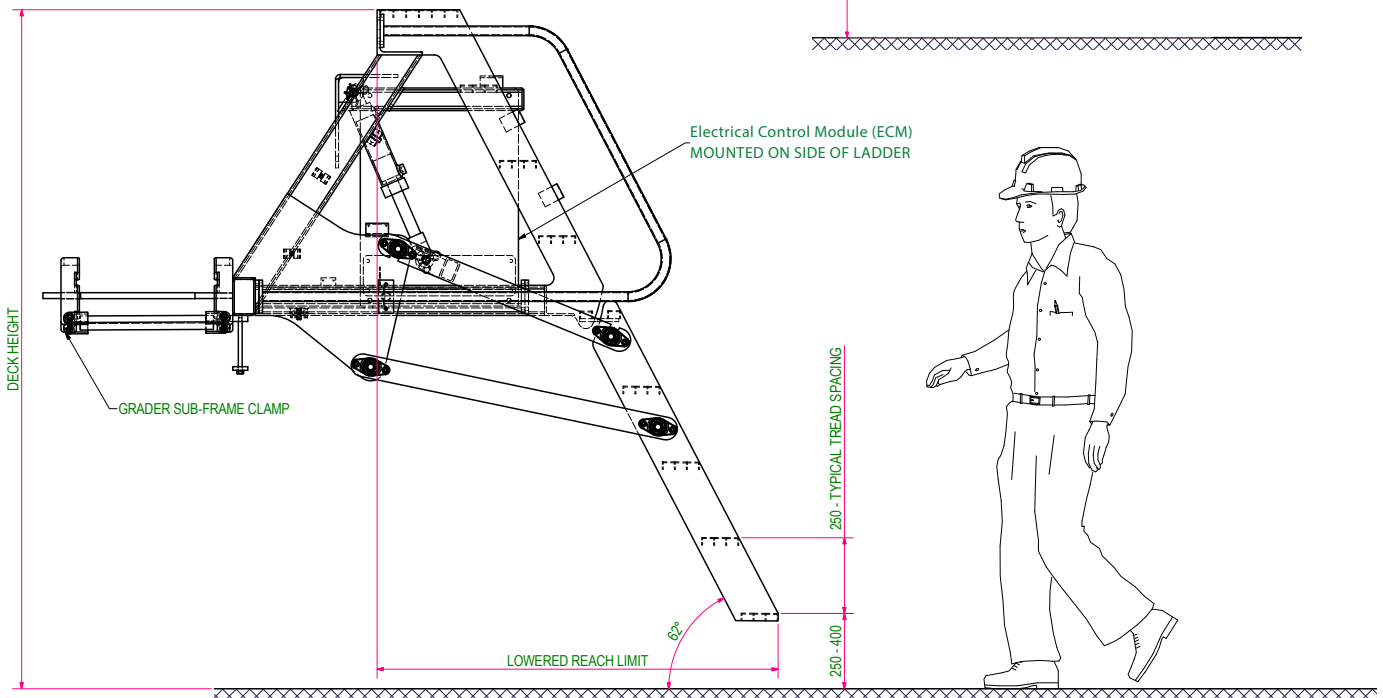
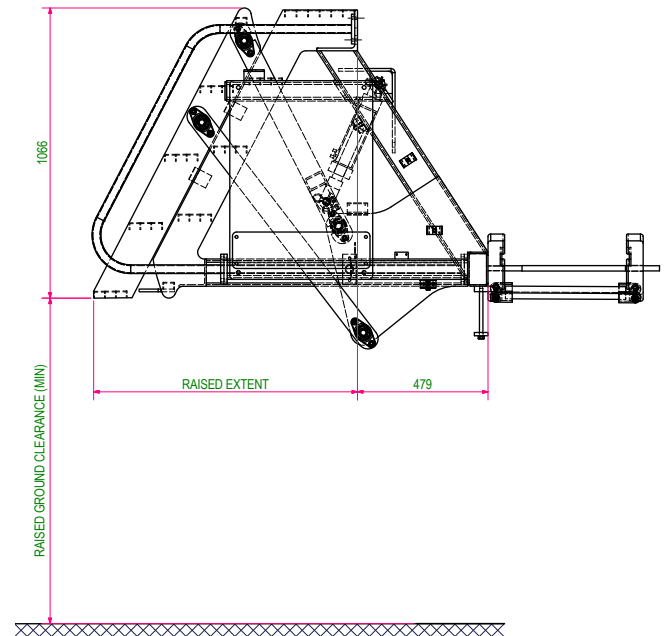
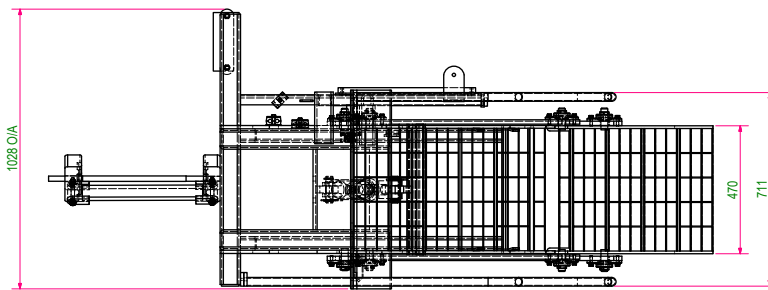

MHG00255 10082021