

# CR20000 Component Rotator

(Part No. TL14100)

The Trilift® CR20000 Component Rotator has been designed and manufactured to enable the handling and rotation of various components including large earthmoving wheel assemblies, final drives, dozer track frames, wheel motors etc.

Working in conjunction with an existing workshop overhead crane, this remote controlled DC powered unit allows maintenance staff to safely and efficiently lift and rotate components within the confines of a single workshop bay.

When used with the Trilift® TH15000 Workshop Tire Handler, the Trilift® CR20000 Component Rotator can safely handle wheel assemblies from large earthmoving and mining equipment.

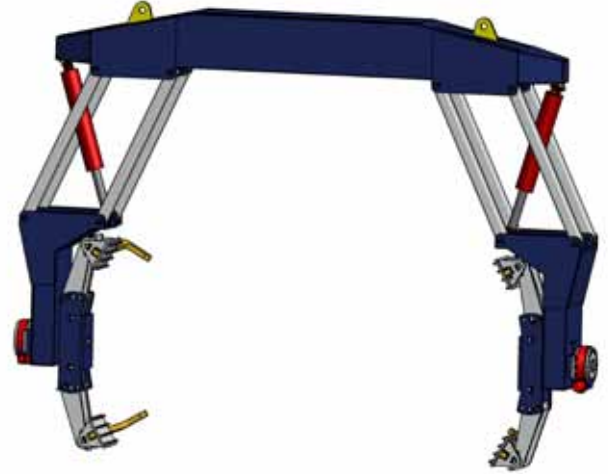

## Features and Benefits

- DC electric/hydraulic powered
- Remote controlled
- 44,092 lbs/20,000kgs W.L.L.
- Utilizes overhead crane
- Handles a range of components using adaptors
- Load and unload directly from the TH15000

## Key Operating Data

Working Load Limit	44,092lbs	20,000kg
--------------------	-----------	----------



Tire rotation up to 20T

Dozer Track Frame rotation for safer maintenance

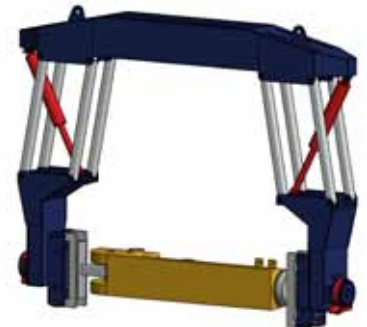

Wheel Motor rotation

