

## Cat 795 Generator Hoist

The Cat 795 Generator Hoist (Part No. TL12020) is a specialised Trilift<sup>®</sup> hoist designed to assist with the removal and installation of Cat 795 generators without removing the truck dump body.



A valuable asset to improve safety and efficiency in all mining and earthmoving workshops

## Features

- The standard Trilift® Cat 795 Generator Hoist is powered by a self-contained Tier IV pollution rated diesel motor powering the hydraulic pump.
- Hydraulic winch with limit valve and brake.
- Emergency stop.
- A stairway and safety rails to allow safe access for personnel from the deck of the truck.
- Counter-balance valves fitted to all hydraulic cylinders.

The main portal frame of the Cat 795 Generator Hoist extends (toward the rear of the truck) to allow connection of the winch to the generator lifting point. When the generator has been removed and winched up into the main portal frame it is then retracted (toward the front of the truck) to allow the hoist, complete with the generator to be lifted off the chassis and placed onto the workshop floor using the overhead crane.

## Functions

- Hoist hydraulic functions:
  - o Winch raise/ lower
  - o Portal Arm forward /back

## Precise control

Hedweld have developed the Cat 795 Generator Hoist to give the operator precise control and accurate movement.

The user-friendly controls have proportional control of the hydraulic valves providing the operator with true feel and millimetre perfect accuracy. By using the controls located on the platform the operator has improved visibility and is removed from the danger zone.



## Safety Benefits and Cost Savings

- Provides a safer working environment for all maintenance staff to assist mine maintenance workshops achieve zero harm.
- Allows all bays in the workshop to be utilised to maximise workshop efficiencies.
- Reduces the number of personnel required to perform maintenance tasks freeing up labour for other duties.
- With the introduction of the Cat 795 Generator Hoist, the maintenance time of your equipment will be decreased. This means that your equipment will be spending less time in the workshop and more time moving overburden and mineral.
- Eliminates the need for dump body removal.
- No mobile cranes required during removal/installation.
- Walkway with handrails for improved safety.



Main Portal Frame

Start position

In motion

Forward position

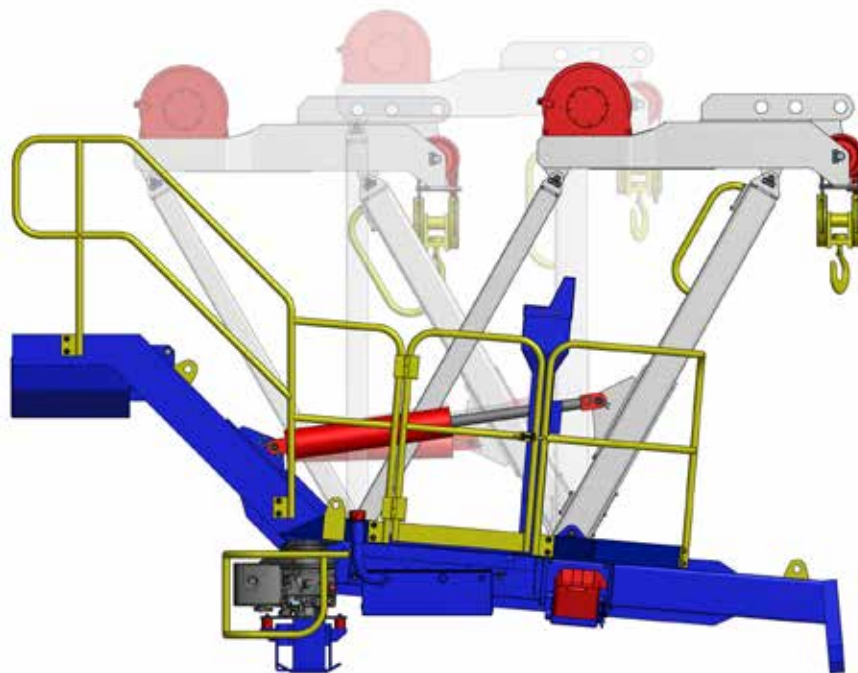

At Hedweld we have a vision that all workshop bays are being used efficiently, utilising specialised tooling that is purpose built for component handling, with the ultimate outcomes of:

**minimising workplace injuries and maximising availability.**

# Specifications

The Trilift® Cat 795 Generator Hoist is compliant with the following standards:

- AS 3990-1993 Mechanical equipment-steelwork.
- AS/NZS 1554.1:2011 Structural Steel Welding.
- AS 1418.1:2002 Cranes, hoists and winches.
- AS/NZS 1163:2009 Structural steel hollow sections.
- AS/NZS 1594:2002 Hot-rolled steel flat products.
- AS/NZS 3678:2011 Structural steel.
- AS/NZS 3679.1:2010 Hot-rolled bars and sections.
- AS/NZS 1252:1996 High strength steel bolts with associated nuts and washers for structural engineering.

## Key Dimensions

A Overall length	3900mm	154in
B Overall width	3700mm	146in
C Overall height	2850mm	112in
D Footprint length	2500mm	98in
E Footprint Width	2020mm	80in
F Internal clearance	1500mm	59in
G Internal chassis width	1720mm	68in
H Portal arm travel	1880mm	74in

## Key Operating Data

Working Load Limit	5000 kg	11023lbs
Tare weight	2800 kg	6173lbs
Power System	Diesel/hydraulic	Hatz IB40V
Hydraulic Relief Pressure	165 bar	2393psi
Includes Transport Frame & Lifting Bracket		

